

# KOMATSU®

## WA900-3E0

**HORSEPOWER**  
638 kW 856 HP @ 2050 rpm

**BUCKET CAPACITY**  
11.5–13.0 m<sup>3</sup> 15.0–17.0 yd<sup>3</sup>

**WA**  
**900**

W  
H  
E  
E  
L  
L  
O  
A  
D  
E  
R



Photo may include optional equipment.

# WALK-AROUND

## ***High Productivity & Low Fuel Consumption***

- High performance Komatsu SAA12V140E-3 engine
- Low fuel consumption
- Dual-mode active working power select system
- Large dumping clearance

See pages 4 and 5.

## ***Excellent Operator Environment***

- Automatic transmission with ECMV
- Tilttable steering column
- “AJSS” (Advanced Joystick Steering System) (Optional)
- Roomy, quiet cab with power windows
- Low vibration & noise
- Pillar-less large cab with ROPS/FOPS canopy
- Comfortable operator’s seat

See pages 8 and 9.

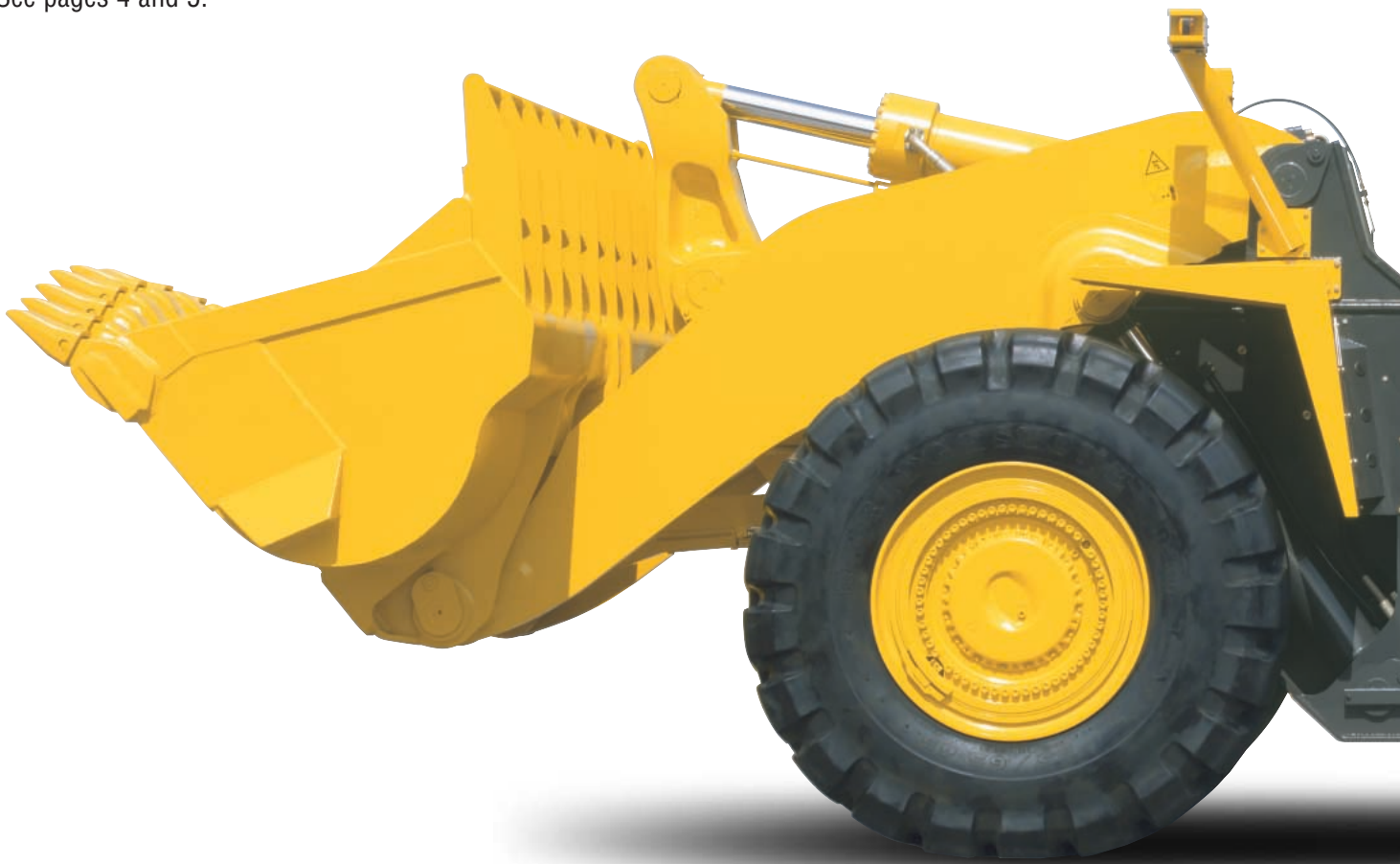

## ***Harmony with Environment***

- EPA Tier 2 emission certified.
- Low fuel consumption

## Reliability

- Reliable Komatsu designed and manufactured components
- Sturdy main frame
- Engine pre-lubrication system (Optional)
- Maintenance-free, fully hydraulic, wet disc brakes

See page 6.

- Hydraulic hoses use flat face O-ring seals
- Cation electrodeposition process is used to apply primer paint.
- Powder coating process is used to apply main structure paint.
- Sealed DT connectors for electrical connections

**HORSEPOWER**  
638 kW 856 HP @ 2050 rpm

**BUCKET CAPACITY**  
11.5–13.0 m<sup>3</sup> 15.0-17.0 yd<sup>3</sup>



Photo may include optional equipment.

## Easy Maintenance

- Simple checks
- "VHMS" (Vehicle Health Monitoring System) (Optional)
- Rear access stairs
- Auto greasing system (Optional)

See page 7.

## HIGH PRODUCTIVITY AND LOW FUEL CONSUMPTION

### High Performance Komatsu SAA12V140E-3 Engine

Electronic Heavy Duty Common Rail fuel injection system provides optimum combustion of fuel. This system also provides fast throttle response to match the machine's powerful tractive effort and fast hydraulic response.

**Net: 638 kW 856 HP**

### Low Emission Engine

This engine is EPA Tier 2 emission certified without sacrificing power or machine productivity.

### Low Fuel Consumption

Low fuel consumption is achieved because of the low-noise, high-torque engine and the large-capacity torque converter with maximum efficiency in the low-speed range.

### Durable Bucket

Komatsu buckets are manufactured using high-tensile strength steel with replaceable welded wear plates for extended bucket life. Additional strength has been added to the bucket bottom corners, side edges and spill guard ends for increased durability.

**Bucket capacity**  
**13.0m<sup>3</sup>** 17cu.yd



### Dual-mode Active Working System

The machine can be equipped with two mode active working system. This system provides the most efficient hydraulic flow for your operation. The active working switch has two modes: powerful loading or normal loading.

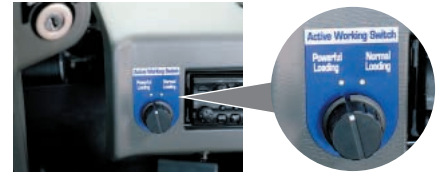

Dual modes switch

#### • Powerful loading mode:

Hydraulic flow towards the work equipment can be increased and reduced as and when required.

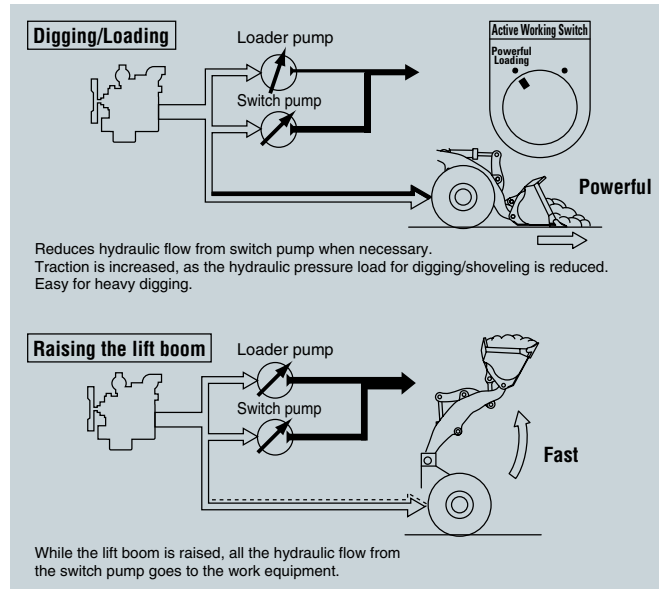

#### • Normal loading mode:

All hydraulic flow is transferred directly to the work equipment.

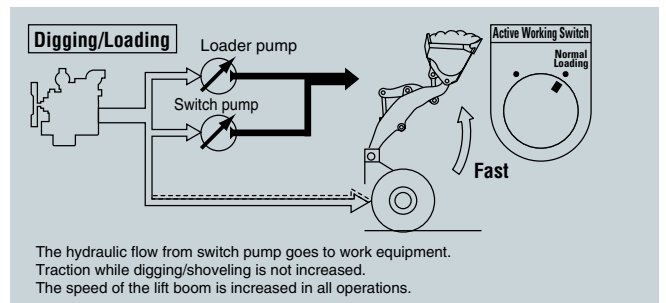



### Large Dumping Clearance

The WA900-3E0 was designed with ample dumping clearance for dump truck matching.

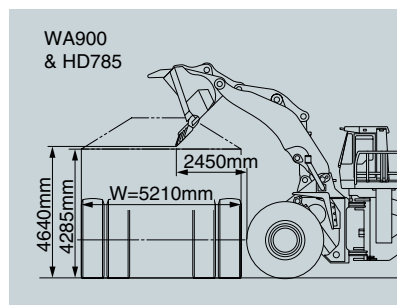

### Excellent Stability

The WA900-3E0 has the widest tread in its class **3,350mm** 11' and a long **5,450mm** 17'11" wheelbase, for maximum machine stability.

### Static tipping load

(with 45/65-45-58 PR (L-5) tires / bucket **13.0 m<sup>3</sup>** 17.0 yd<sup>3</sup>)

Straight: **65670 kg** 144,780 lb

40° full turn: **57430 kg** 126,610 lb

### High Breakout Force

Komatsu wheel loaders have high-tensile steel Z-bar loader linkages for maximum rigidity and maximum breakout force. Sealed loader linkage pins extend greasing intervals.

**Breakout force: 67900 kg** 149,690 lb  
**13.0 m<sup>3</sup>** 17.0 yd<sup>3</sup> Excavating bucket (spade nose) with tipteeth

## INCREASED RELIABILITY

### Komatsu Components

Komatsu manufactures the engine, torque converter, transmission, hydraulic units, electric parts, on this wheel loader. Komatsu loaders are manufactured with an integrated production system under a strict quality control system.

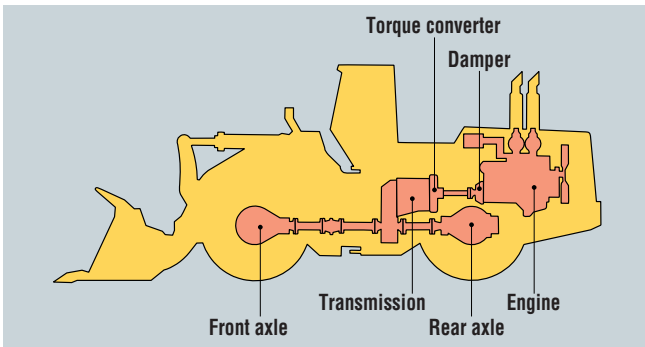

### Engine Pre-lubrication System (Optional)

Durability of the engine is achieved by raising the engine oil pressure before starting the engine. When the operator turns the key, the pre-lubrication pump sends oil from the engine oil pan to the engine oil filter and raises the pressure of that oil to the set pressure. Then, the starting motor rotates to start the engine.

### Maintenance-free Braking System

Service brakes employ two hydraulically-actuated independent circuits which are adjustment-free, fully-sealed, wet disc units, preventing intrusion of dirt and dust. Since the brake system does not use air, it provides many features such as absence of condensation, dependable braking even in cold conditions, no need for drainage, and rust free piping. What's more, charging time after engine starting is drastically shortened and pedal depressing effort is reduced.

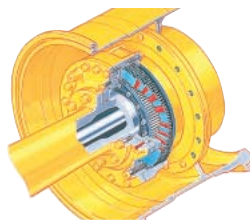

### High-rigidity Frames and Loader Linkage

The front and rear frames and the loader linkage have more torsional rigidity to secure resistance against increased stress. Frame and loader linkage are designed to accommodate actual working loads, and simulated computer testing proves its strength.

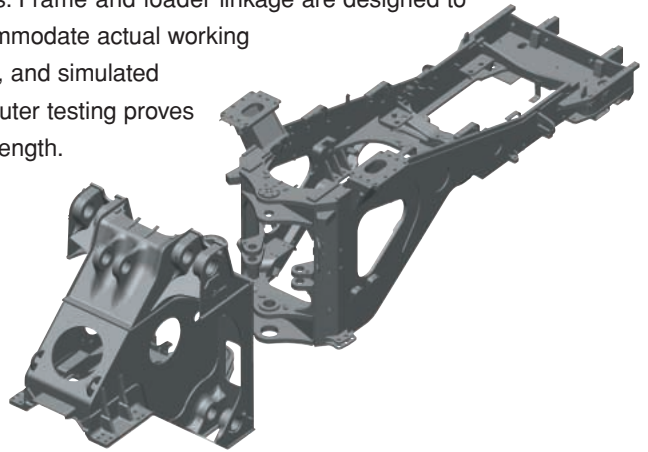

### Flat Face-to-face O-ring Seals

Flat face-to-face O-ring seals are used to securely seal hydraulic hose connections and to prevent oil leakage. In addition, buffer rings are installed to the head side of the all-hydraulic cylinders to lower the load on the rod seals and maximize reliability.

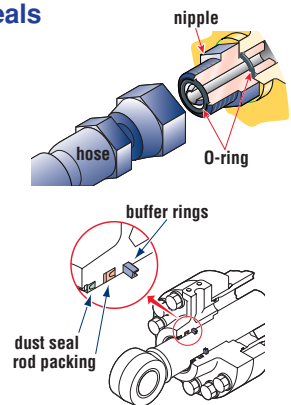

### Cation Electrodeposition Primer Paint/ Powder Coating Final Paint

Cation electrodeposition paint is applied as a primer paint and powder coating is applied as topcoat to the exterior sheet metal parts. This process results in a durable paint finish, even in the most severe environments. Some external parts are made of plastic providing long life and high impact resistance.

### Sealed DT Connectors

Main harnesses and controller connectors are equipped with sealed DT connectors providing high reliability, water resistance and dust resistance.



# EASY MAINTENANCE



Photo may include optional equipment.

### Simple Checks, Easy Maintenance

The main monitor and the maintenance monitor (EDIMOS II) are neatly arranged on the instrument panel for a quick, clear reading of machine functions at all times. The main monitor also has a diagnostic function.

#### Main monitor



#### Maintenance monitor



### Large Side Door

Right side door is easy to open and provides accessibility for maintenance.



### Fuel Tank Cap with Mud Cover and Large Tool Box

Fuel tank cap



Tool box



### Rear Access Stairs

For the purpose of boarding and exiting machine, rear access stairs with handrail is provided. The step width, clearance, and the step angle have been designed for climbing both up and down. A step light provides light for night boarding.



### Auto-greasing System (Optional)

The periodic lubrication points, except for drive shaft, are greased automatically according to a preset amount and interval. Quick-change grease canisters make replacement easy and clean.

### VHMS (Vehicle Health Monitoring System) (Optional)

VHMS is a management system for large equipment for use in mining, which enables detailed monitoring of fleet via satellite communications. Komatsu and distributors can analyze "vehicle health" and other operating conditions and provide the information to job site using the internet from a remote location on a near-real time basis.

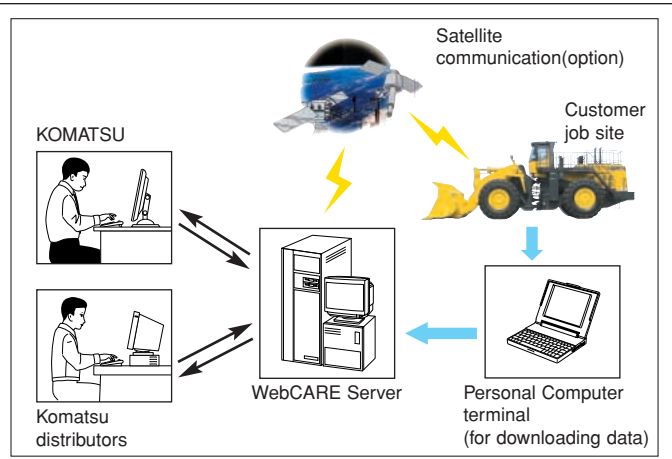

# OPERATOR ENVIRONMENT

## Easy Operation

### Automatic Transmission with Electronically Controlled Modulation Valve (ECMV)

Automatic transmission with ECMV automatically selects the proper gear speed based on travel speed, engine speed, and other travel conditions. The ECMV system engages the clutch smoothly to prevent lags and shocks when shifting. This system provides efficient machine operation and a comfortable ride.

● **Kick-down switch:**

This valuable feature for increases productivity. With the touch of a finger, the kick-down switch automatically downshifts from second to first when beginning the digging cycle. It automatically upshifts from first to second when the direction control lever is placed in reverse. This results in increased rim pull for better bucket penetration and reduced cycle times for higher productivity.

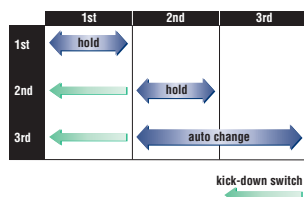

● **Hold switch:** Auto shift is selected and if the operator turns on this switch when the lever is at the 3rd gear speed position, the transmission is fixed to that gear speed.

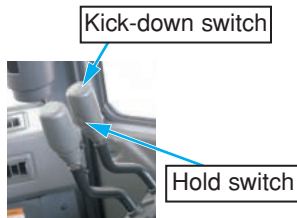

### Electronically Controlled Transmission Lever

Easy shifting and directional changes with Komatsu two-lever electronic shifting. Change direction or shift gears without removing the shifting hand from the steering wheel. Solid state electronics and conveniently located direction and gear shift controls make this possible. Automatic shifts in ranges two through four keep production high and manual shifting at a minimum.



### Steering Wheel Type



### Tiltable Steering Column & One-glance Monitors

The steering column can be easily tilt-adjusted to the most comfortable position with one lever.



### Variable Transmission Cut-off System

The operator can set the transmission cut-off pressure desired for the left brake pedal using the switch located on the right-side control panel. The operator can improve the working performance by setting the cut-off pressure properly depending on working condition.

- High cut-off pressure for digging operations.
- Low cut-off pressure for truck-loading operations.



1:T/M cut-off ON/OFF switch  
2:T/M cut-off set switch



**Remote Boom Positioner**

The highest and lowest position of the bucket can be set from the cab to match any truck body. Once the positioner is set, the bucket is smoothly stopped at desired position with no shock.

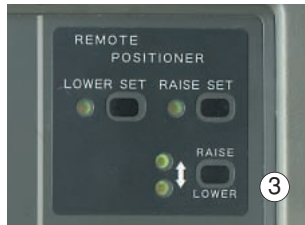

3: Remote boom positioner switch

**AJSS (Advanced Joystick Steering System) (Optional)**

AJSS is a feedback steering system which has been incorporated to allow steering and forward and reverse selection to be controlled by wrist and finger control. With the feedback function, the machine steering angle is exactly the same angle as the lever tilt angle.

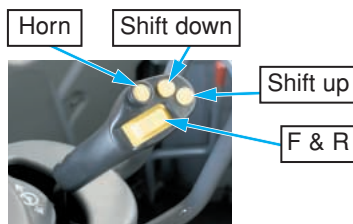

**Comfortable Operation**

**Roomy, Quiet Cab with Power Windows**

The cab is large, with a comfortably spacious interior and power windows. Also, a wide viewing angle is guaranteed because the cab is pillar-less. By adopting a high-capacity air conditioner, Komatsu ensures operator comfort, no matter the exterior conditions. Other features designed with operators in mind include a lunchbox storage space.



Lunchbox storage space

**Low Vibration & Noise**

The cab rests on Komatsu viscous damping mounts (rubber and silicon oil) to reduce vibration and noise. All hydraulic equipment is mounted on high-resistance rubber to further reduce vibration and noise.

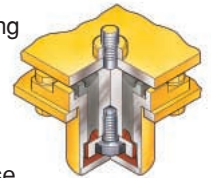

**Pillar-less Large Cab with ROPS / FOPS Canopy**

A wide pillar-less flat glass provides excellent front visibility. The wiper arm covers a large area to provide great visibility even on rainy days.



Rear heated glass provides clear view even in freezing or condensation conditions.



**Comfortable Operator's Seat**

The operator's seat has a reclining/air suspension design with headrest to support the operator comfortably during long operation. Also, it is easy to adjust seat height with air suspension.



## SPECIFICATIONS



### ENGINE

Model .....Komatsu SAA12V140E-3  
 Type .....Water-cooled, 4-cycle  
 Aspiration .....Turbocharged, air-to-air aftercooled  
 Number of cylinders .....12  
 Bore x stroke .....140 mm x 165 mm 5.51" x 6.50"  
 Piston displacement .....30.48 ltr 1860 in<sup>3</sup>  
 Governor .....All-speed, electronic  
 Horsepower  
 SAE J1995 .....Gross 672 kW 900 HP  
 ISO 9249/SAE J1349 .....Net 638 kW 856 HP  
 Rated rpm .....2050 rpm  
 Fan drive method for radiator cooling .....Mechanical  
 Fuel system .....Direct injection  
 Lubrication system:  
 Method .....Gear pump, force-lubrication  
 Filter .....Full-flow and bypass combined  
 Air cleaner .....Dry type with automatic dust ejector  
 and pre-cleaner, cyclopac with vacuator

EPA Tier 2 emission certified.



### TRANSMISSION

Torque converter:  
 Type .....3-element, single-stage, single-phase  
 Transmission:  
 Type .....Full-powershift, planetary type  
 Travel speed: km/h mph  
 Measured with 45/65-45-58 tires

	1st	2nd	3rd
Forward	7.0 4.3	12.3 7.6	28.0 17.4
Reverse	7.1 4.4	12.4 7.7	28.3 17.6



### AXLES AND FINAL DRIVES

Drive system .....Four-wheel drive  
 Front .....Fixed, full-floating  
 Rear .....Center-pin support, full-floating,  
 22° total oscillation  
 Reduction gear .....Spiral bevel gear  
 Differential gear .....Straight bevel gear  
 Final reduction gear .....Planetary gear, single reduction, oil bath



### BRAKES

Service brakes .....Hydraulically actuated,  
 wet disc brakes actuate on four wheels  
 Parking brake .....Dry disc brake  
 Emergency brake .....Parking brake is commonly used



### STEERING SYSTEM

Type .....Articulated type, full-hydraulic power steering  
 Steering angle .....40° each direction  
 Minimum turning radius at  
 the center of outside tire .....9200 mm 30'2"



### HYDRAULIC SYSTEM

Steering system:  
 Hydraulic pump .....Piston pump  
 Capacity .....315 ltr/min 83.2 U.S. gal/min at rated rpm  
 Relief valve setting .....34.3 MPa 350 kgf/cm<sup>2</sup> 4,977 psi  
 Hydraulic cylinders:  
 Type .....Double-acting, piston type  
 Number of cylinders .....2  
 Bore x stroke .....160 mm x 503 mm 6.3" x 19.8"  
 Loader control:  
 Hydraulic pump .....Piston pump  
 Capacity .....415 ltr/min 109.6 U.S. gal/min  
 at rated rpm  
 Relief valve setting .....34.3 MPa 350 kgf/cm<sup>2</sup> 4,977 psi  
 Hydraulic cylinders:  
 Type .....Double-acting, piston type  
 Number of cylinders—bore x stroke:  
 Lift cylinder .....2- 260 mm x 1368 mm 10.2" x 53.9"  
 Bucket cylinder .....1- 300 mm x 906 mm 11.8" x 35.7"  
 Control valve .....Spool type  
 Control positions:  
 Boom .....Raise, hold, lower, and float  
 Bucket .....Tilt-back, hold, and dump  
 Hydraulic cycle time (rated load in bucket)  
 Raise .....11.2 sec  
 Dump .....2.0 sec  
 Lower (Empty) .....4.8 sec



### ROPS / FOPS & CAB

Structure complies with ISO 3471 ROPS (Roll-Over Protective Structure) standards, as well as ISO 3449 FOPS (Falling Object Protective Structure) standards. The cab is mounted on rubber pads and is well insulated.



### SERVICE REFILL CAPACITIES

Cooling system .....337 ltr 89.0 U.S. gal  
 Fuel tank .....1555 ltr 410.8 U.S. gal  
 Engine .....130 ltr 34.3 U.S. gal  
 Hydraulic system .....725 ltr 191.5 U.S. gal  
 Axle (each front and rear) .....360 ltr 95.1 U.S. gal  
 Torque converter and transmission .....140 ltr 37.0 U.S. gal



### BUCKET SELECTION GUIDE

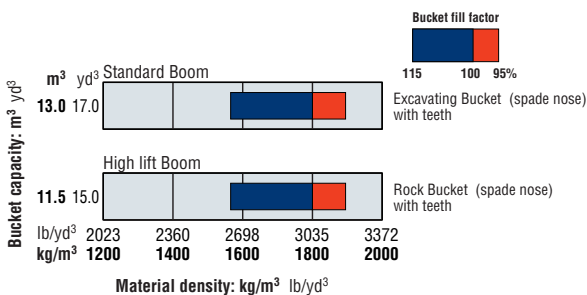



**DIMENSIONS**

Measured with 45/65-45-58PR(L-5) tires

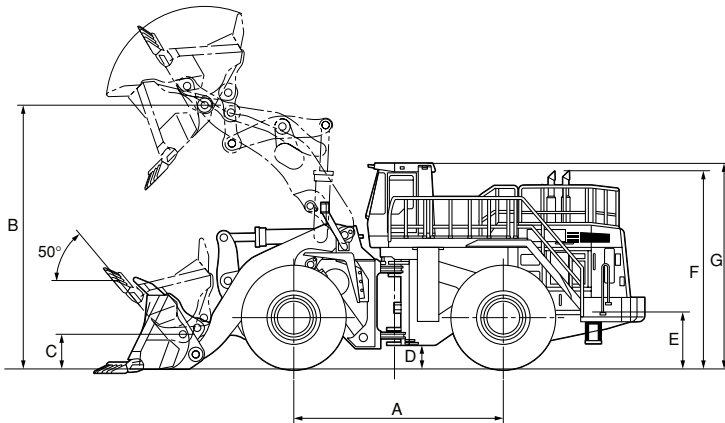

	Standard Boom	High lift Boom
Tread	<b>3350 mm 11'</b>	
Width over tires	<b>4585 mm 15'1"</b>	
A Wheelbase	<b>5450 mm 17'11"</b>	
B Hinge pin height, max. height	<b>6960 mm 22'10"</b>	<b>7445 mm 24'5"</b>
C Hinge pin height, carry position	<b>800 mm 2'7"</b>	
D Ground clearance	<b>550 mm 1'10"</b>	
E Hitch height	<b>1390 mm 4'7"</b>	
F Overall height, top of the stack	<b>5130 mm 16'10"</b>	
G Overall height, ROPS cab	<b>5275 mm 17'4"</b>	

	Standard boom	High lift boom
	Excavating Bucket	Excavating Bucket
	Spade nose Tipteeth	Spade nose teeth
Bucket capacity: heaped	<b>13.0 m<sup>3</sup></b> 17.0 yd <sup>3</sup>	<b>11.5 m<sup>3</sup></b> 15.0 yd <sup>3</sup>
struck	<b>11.0 m<sup>3</sup></b> 14.4 yd <sup>3</sup>	<b>9.7 m<sup>3</sup></b> 12.7 yd <sup>3</sup>
Bucket width	<b>4810 mm</b> 15'9"	<b>4810 mm</b> 15'9"
Bucket weight	<b>12330 kg</b> 27,180 lb	<b>11370 kg</b> 25,070 lb
Dumping clearance, max. height and 45° dump angle	<b>4640 mm</b> 15'3"	<b>5255 mm</b> 17'3"
Reach at max. height and 45° dump angle	<b>2450 mm</b> 8'	<b>2235 mm</b> 7'4"
Reach at 2130 mm (7') clearance and 45° dump angle	<b>3650 mm</b> 12'	<b>4020 mm</b> 13'2"
Reach with arm horizontal and bucket level	<b>4640 mm</b> 15'3"	<b>4760 mm</b> 15'7"
Operating height (fully raised)	<b>9680 mm</b> 31'9"	<b>9875 mm</b> 32'5"
Overall length	<b>14490 mm</b> 47'6"	<b>14685 mm</b> 48'2"
Loader clearance circle (bucket at carry, outside corner of bucket)	<b>22000 mm</b> 72'2"	<b>22200 mm</b> 72'10"
Digging depth: 0°	<b>165 mm</b> 6.5"	<b>160 mm</b> 6.3"
10°	<b>645 mm</b> 2'1"	<b>610 mm</b> 2'0"
Static tipping load: straight	<b>65670 kg</b> 144,780 lb	<b>62540 kg</b> 137,880 lb
40° full turn	<b>57430 kg</b> 126,610 lb	<b>55030 kg</b> 121,320 lb
Breakout force	<b>666 kN</b> 67900 kgf 149,690 lb	<b>703 kN</b> 71700 kgf 158,070 lb
Operating weight	<b>107200 kg</b> 236,340 lb	<b>107350 kg</b> 236,670 lb

All dimensions, weights, and performance values based on SAE J732c and J742b standards.

Static tipping load and operating weight shown include lubricant, coolant, full fuel tank, ROPS canopy, air conditioner, bucket and operator. Machine stability and operating weight are affected by counterweight, or ballast, tire size, and other attachments.

Use either counterweight or ballast, not both. Apply the following weight changes to operating weight and static tipping load.



## WEIGHT CHANGES

	Operating weight		Tipping load			
			Straight		Full turn	
Remove ROPS canopy	<b>-1385 kg</b>	-3,055 lb	<b>-1220 kg</b>	-2,690 lb	<b>-1180 kg</b>	-2,600 lb
Remove steel cab	<b>-430 kg</b>	-950 lb	<b>-335 kg</b>	-740 lb	<b>-330 kg</b>	-730 lb



## STANDARD EQUIPMENT

- 2-spool valve for boom and bucket controls
- Alternator, 90 A/24 V
- Air conditioner
- Automatic transmission F3 / R3
- Back-up alarm
- Back-up lamp
- Batteries, 160 Ah/12 V x 4
- Boom kick-out
- Bucket positioner
- Counterweight
- Directional signal
- Emergency brake
- Engine, Komatsu SAA12V140E-3 diesel
- Floor mat
- Front working lights (2)
- Hard water area arrangement (corrosion resister)
- Head lights (2)
- Lift cylinders and bucket cylinder
- Radiator mask, lattice type
- Rear access stairs
- Rear defroster (electric)
- Rearview mirrors
- Rear window washer and wiper
- Rear working lights (2)
- Room mirror
- ROPS/FOPS canopy
- Seat belt
- Seat, suspension type with reclining
- Service brakes, wet disc type
- Side working lights (2)
- Standard boom
- Starting motor, **7.5 kW**/24 V x 2
- Steel cab included front wiper, windshield washer and power window
- Steering wheel, tiltable
- Sun visor
- Tires (45/65-45-58PR L-5 tubeless) and rims
- Water separator



## OPTIONAL EQUIPMENT

- AJSS (advanced Joystick Steering System)
- AM/FM radio
- AM/FM stereo radio cassette
- Ashtray and cigarette lighter
- Automatic greasing
- Bucket corner teeth
- Bucket teeth (weld-on/tip type)
- Counterweight for high lift boom
- Emergency steering (SAE)
- Engine pre-lube system
- Fast fill fuel system
- Fenders
- Fire extinguisher
- Heater and defroster
- High lift boom
- Mesh chain
- Ordinary spare parts
- Power train guard
- Rear under view mirror
- Sweeper wing
- Tires (45/65-R45 L-5 tubeless)
- Tool kit
- Under view mirror
- Vandalism protection
- VHMS (Vehicle Health Monitoring System)
- Yellow rotating lamp

# KOMATSU®